

How To Guide

Fitting Guide for Glidemotion rail with RIB Seat T5/T6 or Transit custom

Disclaimer: Please be aware that this guide is exactly that, a guide, to support you during the fitting process.

This guide is not a replacement for your own diligence, please ensure you check and double check the position of your rails, both inside and on the underside before making any cuts or drilling the van floor.

Glidemotion Seat and Rail

Once you receive your seat and rail system the first thing to check is that the design locks off and works correctly. The seat and rails have been pre-checked before we dispatch to ensure they pair up correctly, but a second check is worthwhile before installation commences.

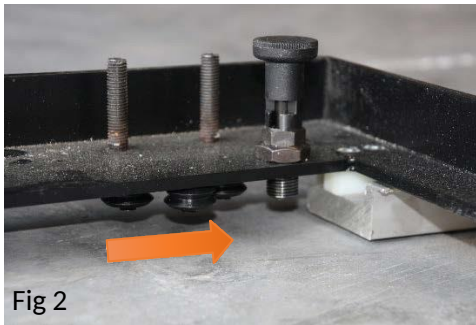
Firstly, the rails should be set on flat ground and laid parallel. Now slide the sledge frame into the rail housing. The rails are handed left and right with the large holes in the rails on the outer edge of each rail. (Fig1). For orientation; the index plungers are at the front of the frame, and the front of the rails can have a 6mm threaded hole 20mm from the end.

Care should be taken when the seat is slid into the rails, the front V-shape bearings should slide and lock into the side of the rails. The sledge should be slid in from the back of the rails.

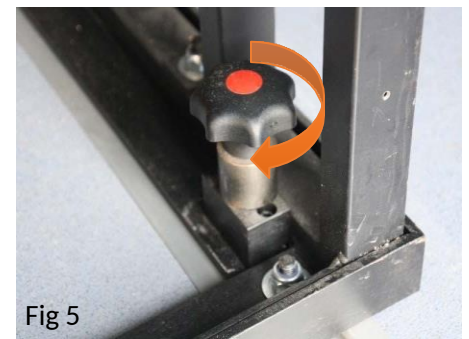


Fig 1

(Fig.2) Make sure that the frame is then pushed forward squarely. The back set of bearings should then also slide into place (Fig.3) thus taking the weight of the frame and allowing the smooth gliding of the frame within the rails.



The front lock off plungers should now be disengaged from their resting position and the frame slid forward until both plungers firmly lock off in place. Lift the seat onto the frame and make sure it drops flat onto the frame. (Fig.4)



Once the plungers have locked into place, the lock off handles should be depressed and turned to tighten down the seat on to the rails. (Fig. 5) Continue to turn the handle until it is fully wound down. (Do not over tighten, only a light lock is required)

Unthread the lock off handles and front lock off plungers to free the seat to slide forward or back, repeat the lock off process for the other seat positions on the rail to check for correct alignment. Once all the lock off points have been checked remove the seat from the lower frame and set the seat to one side.

Floor Preparation

With no ply floor present use the front and rear fitting templates supplied to mark the approximate position of the rails on the floor. In the area under where the rails will be fitted fit the floor corrugation with the 9mm thick ply strips provided. (Fig.6)

This will ensure the rails remain flat and won't twist when fixed in place. The strips can be glued with a flexible polyurethane glue such as Sikaflex 221. Make sure that when glued in the strips don't protrude above the highest point of the ribbed metal floor.

GlideMotion V2.0

Changes to sledge design

Our inhouse design team are continually looking at how to improve our products. We are now proud to offer the GlideMotion 2.0 rail system. The focus of our 2.0 design was to improve useability and further strengthen the overall design.



We have relocated the wind down star grip to a position further forward. This enables customers to more easily access the handle from the front of the van when they lift the front cushion.



We have also strengthened the sledge system by incorporating a sliding steel foot enclosed within the rail track. This additional feature allows for 90% integral strength even if the threaded lock down handle isn't engaged. This eliminates user error to provide a super safe sliding system with easy operation and lock-off.



Important fitting instruction

We will send your sledge with this steel foot loosely fitted, the process from here is to fit the sledge onto the rails, housing the bottom of the steel foot into the rail system.

Once in place, remove the top of this steel foot and place the seat into position inside the sledge, ensuring the bolts and stems line up, once in place you can re-seat the top part of the steel foot, ensuring that the bolts are only done up finger tight, this should ensure that there is enough movement in the foot that its super smooth but not too loose to create excessive chatter.

As you'd expect our GlideMotion rails still provide beautifully smooth bearing assisted motion, with no rattle lock down. Pairing our rail system with the market leading RIB Altair has allowed us to produce a product that is unsurpassed in build quality and function at an unbeatable price.

01271 373853

enquiries@clearcutconversions.co.uk

www.clearcutconversions.co.uk



Fig 6 – This shows how the packers need to be placed for the fitting of RIB GlideMotion 112cm

Note – Additional packers can be used, for reference see images on final page of this guide.



Fig 7 – This shows how the packers need to be placed for the fitting of RIB GlideMotion 150cm

4-5mm of sheet foam insulation is required to achieve the correct floor thickness for the rails. (This can be purchased separately from us)

It will be best to glue the foam insulation in place with spray glue. Make sure the foam insulation is neatly fitted and any joints of the foam sheet do not overlap to cause high points on the floor.

Next, cut a 18mm ply sheet to fit the van floor snugly (Fig. 8) -you can use your old floor as a template for this. When cut, lift the complete sheet into the van and lie in position. (the floor can be fitted in multiple pieces if needed – this is often the case in lwb vans). However, a single piece avoids any joints showing through the floor vinyl when completed.



Lie the supplied templates onto the ply floor at the front and back of the van. (Fig.9). These will indicate where the rails and sledge need to be positioned. Place the rails and sledge into the van. The rails can be drawn around with a pencil to transfer their position onto the ply floor.

The floor can then be removed from the van and rail channels can be cut into the ply floor. (Fig.10) Lift the floor back into the van and check that the rails and sledge fit comfortably in the cut channels of the floor.

- Check the sledge slide smoothly along the rails without binding.
- Check the rail front lock off points engage correctly and fully.



Fig 10



Fig 11



Fig 12

The Vinyl or Altro flooring should be fitted onto the ply floor using a high temp spray adhesive or spreadable adhesive (See our other how to guides for handy tips on fitting an Altro top covering).

Once the Altro covering is fitted then the insulating sheet under the ply floor should be cut away in the rail channels so that the rails sit directly on the metal floor and mdf spacers. (Fig.11 - 2 seater / Fig. 12 - 3 seater)

Fitting the Rails, Frame and Seat

Before proceeding any further the fuel tank and exhaust heat shield will need to be dropped to gain access to the underside of the floor.

To drop the fuel tank (Fig.13) undo the support brackets and carefully lower.

The fuel inlet feeder tube will also need to be undone and loosened allowing the tank to drop. (Fig.14)

The exhaust and heat shield will also need to be dropped to gain access to fit the nut, washers and spreader plates. (Fig.15). The exhaust joint connections may need disconnecting to lower the exhaust sufficiently.



F Fig 13

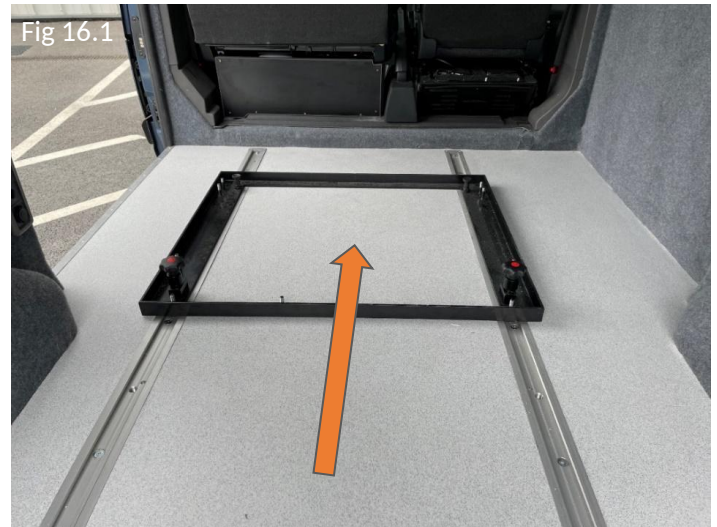


Fig 14



Fig 15

Once the fuel tank has been dropped, lock off the frame at the rear of the van (Fig. 16) using both the plungers and the sprung loaded threaded bolts. Drill the two rear most holes through the floor of the van and push in 2 x countersunk bolts to secure position.



Now unlock the sledge frame and slide to the front of the rails, lock off the sledge frame toward the front in a position (Fig. 19) that still exposes the most forward countersunk hole in the rails. Once the seat is locked off on the rails carefully drill through the 2 most forward countersunk holes. An extra-long 10mm drill bit may be needed as the drill will pass through the main chassis beam on the passenger side. (VW Transporter only). Now push a M10 countersunk bolt into the hole on each rail.

With these 4 holes drilled and located check the frame slides smoothly up and down the van, if it does not, then it may be that the rail is binding on the side of the ply floor. In which case the rails and frame will need to be removed and the ply cut back slightly in the area where it is binding. Once you're happy the seat locks off as required along its length, Lightly tighten the 2 front bolts and 2 rear bolts to hold the rails in position.

- Where the longer bolts (130mm) pass through the chassis beam on the passenger front side use a penny washer and nylock nut.
- Elsewhere the shorter bolts (50mm) pass through the floor of the van and require a 100mm spreader plate.

(At this point you may wish to lift the seat in place and check that the seat slides without fouling any furniture planned)

Check again that the seat locks off in the required positions.

N.B. It is very important that the rails are aligned front to back. The front lock off points should lock off and engage at exactly the same time (One single click noise) as the frame is slowly pushed forward. If one side locks off before the other we recommend that the driver side bolt holes are enlarged to allow for the slight adjustment necessary.

The remaining holes can now be drilled by carefully moving the sledge along the rails and locking off the sledge to ensure the rail holes are drilled in the correct positions.

The supplied washers and spreader plates can be added to the underside of the van. The bolts should be lightly done up in a manner and order that does not distort the rail position. i.e. Tighten middle bolts first and work toward the front and back.

The seat can now be lifted into the van and dropped on to the frame. (Fig. 17) The nuts are then tightened onto the seat frame to secure the seat in place. (Lightly tighten the nuts. Do not over tighten the nuts). We recommend that the front and rear cushions are left off when fitting the seat to the frame, this cuts down on weight and makes the alignment easier. Once the seat is bolted in place then add the front and rear cushions following the seat manufacturers' instructions.



Fig 17

A final check is then made to ensure all the front and rear lock off points are working correctly. The nuts underneath the floor can now be tightened a little more. do not over tighten as this may distort the track alignment and cause problems with the seat sliding freely. We recommend a torque setting of 10-15Nm.

The end caps can now be added behind and in front of the rails to cover any gap at the end of the rail in the ply floor. (Fig.18)



Fig 18



The sliding movement of the seat on the rails can further be improved with spraying the inside of the rails with a suitable silicone lubricant spray.

Under seat storage can also be added to the seat to allow storage of bulky items (Max load 20Kg)

Rails V2.0

* Important note *

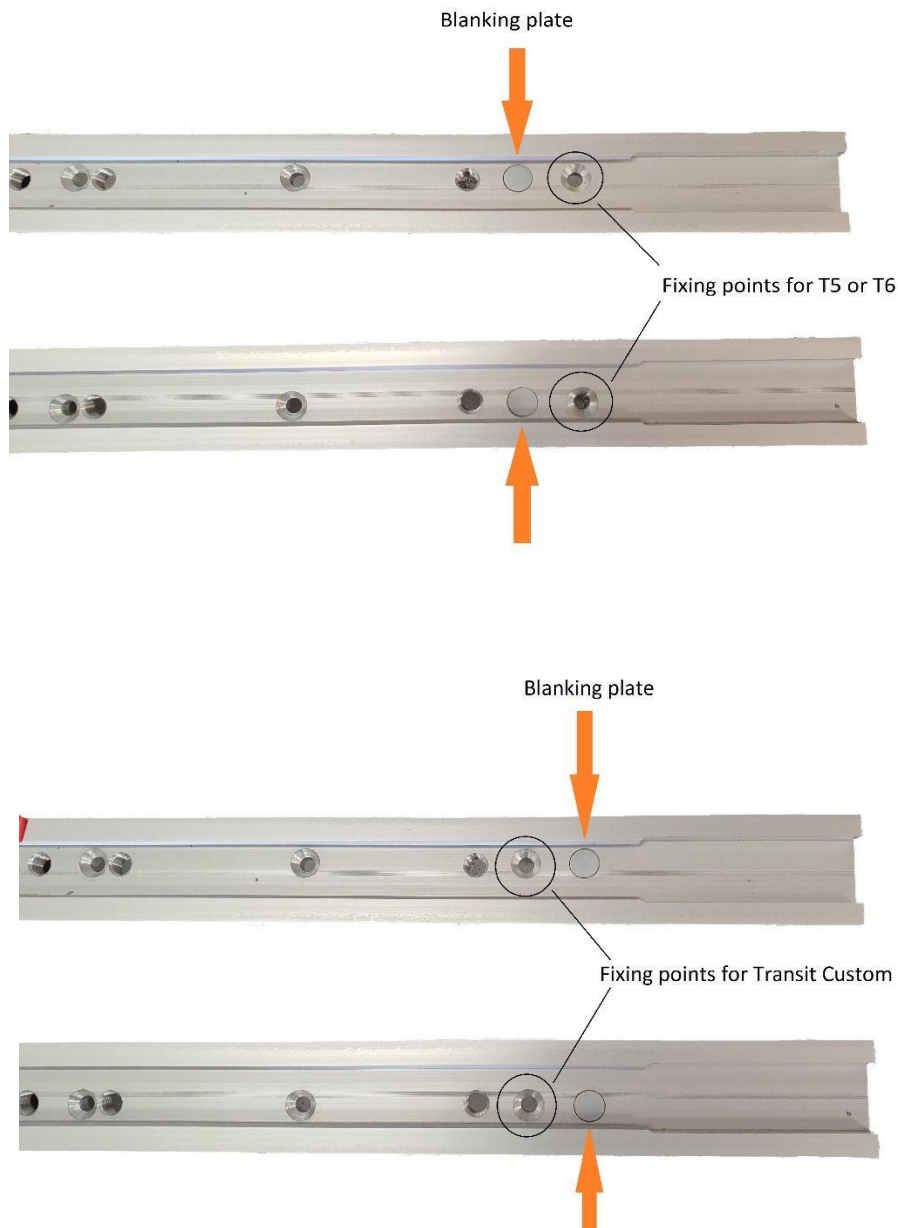
As of **31.10.22** the design of our RIB seat rail system has been improved.

The images below highlight the main difference in that the rail is now suitable for either the VW or the Transit Custom, but not all bolt locations are required when fixing down.

When you ordered, we will have asked which vehicle these are for, and then once delivered you will find that the fixing you don't need will be capped off, as per images below.

There is also an additional lock-off position at the midway point which we have added. This is to improve access to cupboards when the Glidemotion rails are fitted with side furniture.

This means that there are now 6 lock-off points for the SWB version.



01271 373853

enquiries@clearcutconversions.co.uk

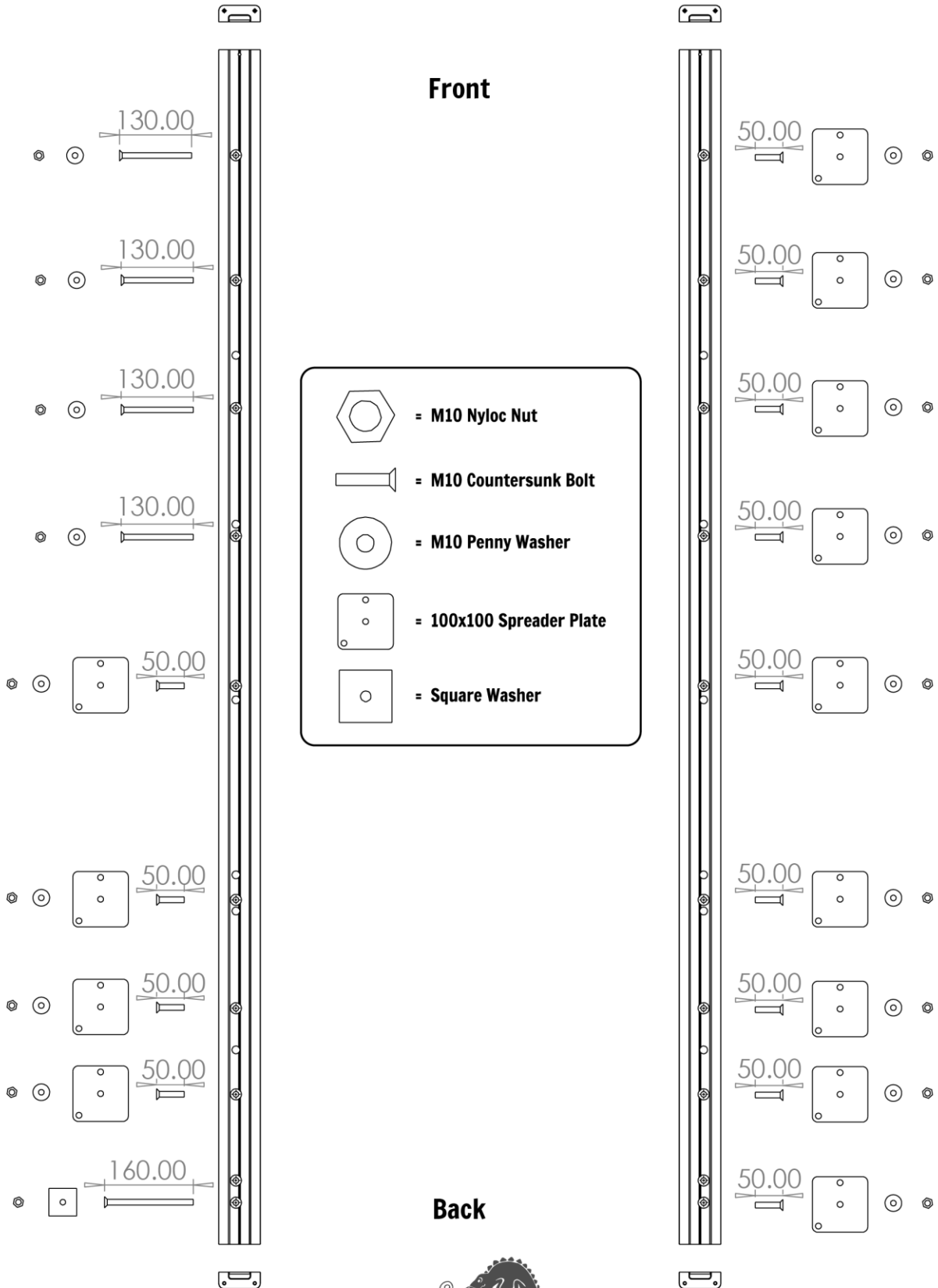
www.clearcutconversions.co.uk

RIB 112 Glidemotion SWB T5/6 Fixings Guide

Passenger Side

Drivers Side

Front

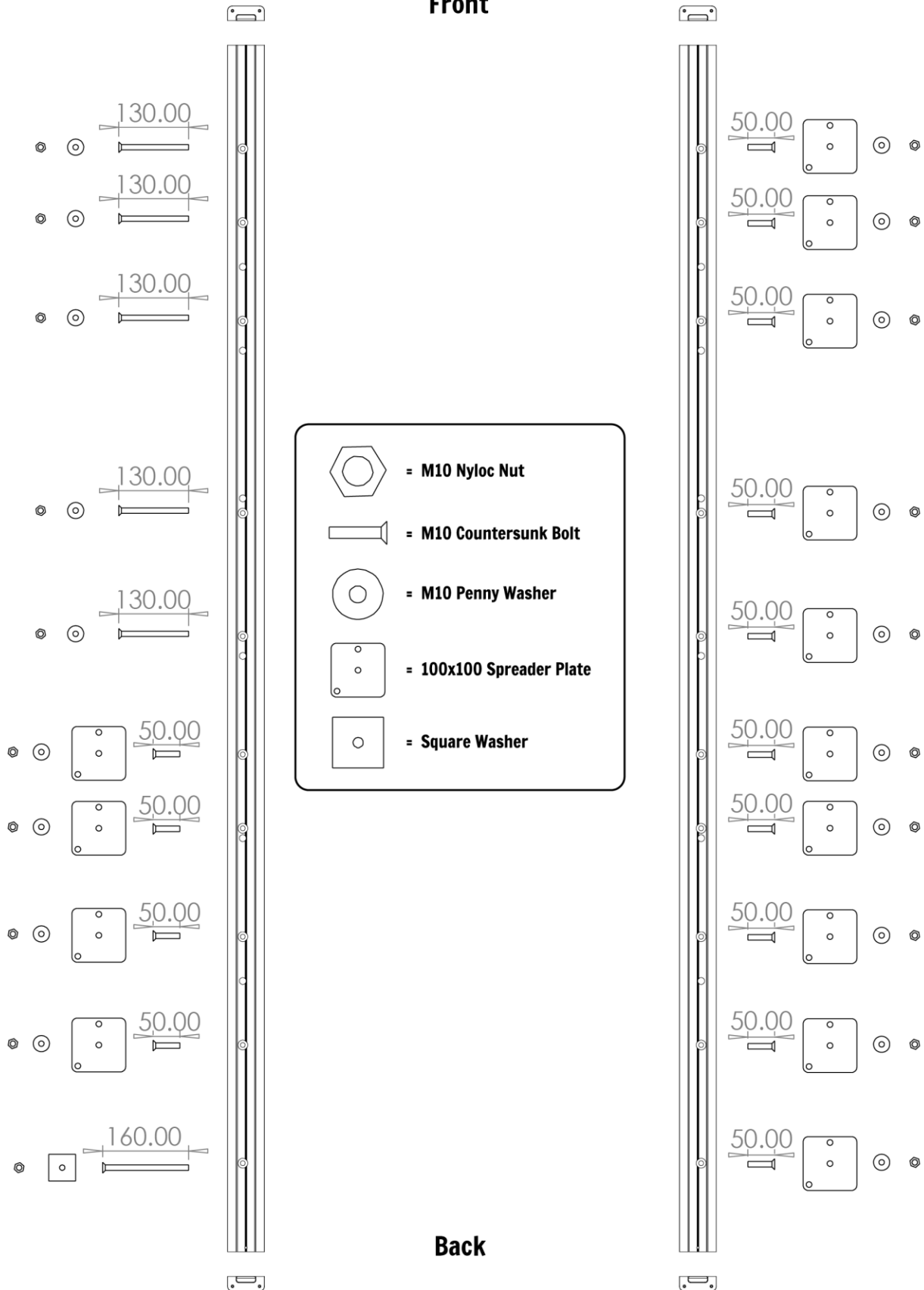


	= M10 Nyloc Nut
	= M10 Countersunk Bolt
	= M10 Penny Washer
	= 100x100 Spreader Plate
	= Square Washer

Back

RIB 112 Glidemotion LWB T5/6 Fixings Guide

Front



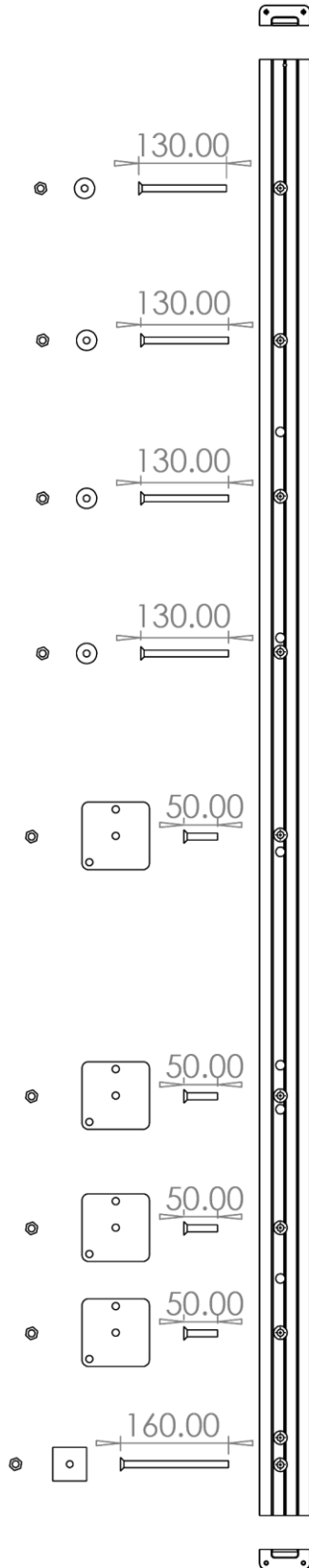
Back






RIB 120 Glidemotion SWB T5/6 Fixings Guide

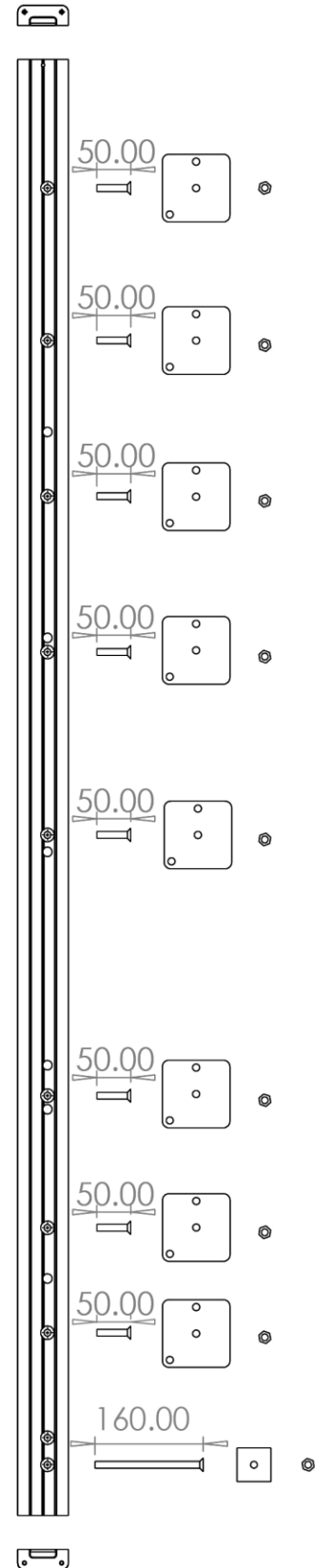
Passenger Side

Drivers Side

Front



	= M10 Nyloc Nut
	= M10 Countersunk Bolt
	= M10 Penny Washer
	= 100x100 Spreader Plate
	= Square Washer



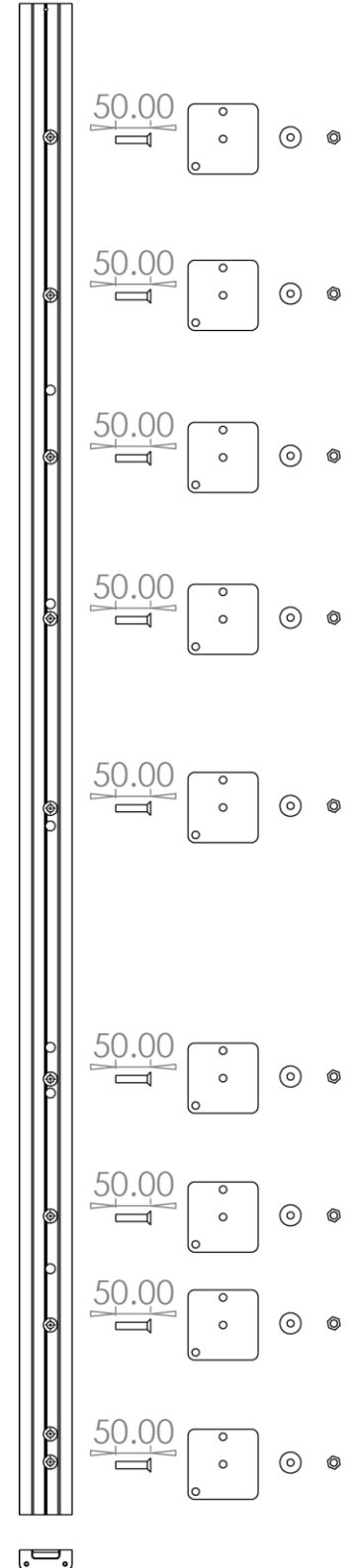
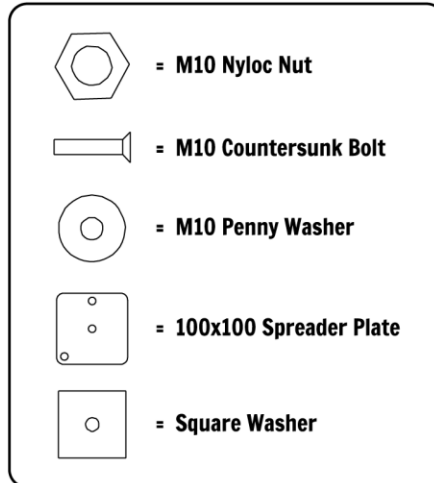
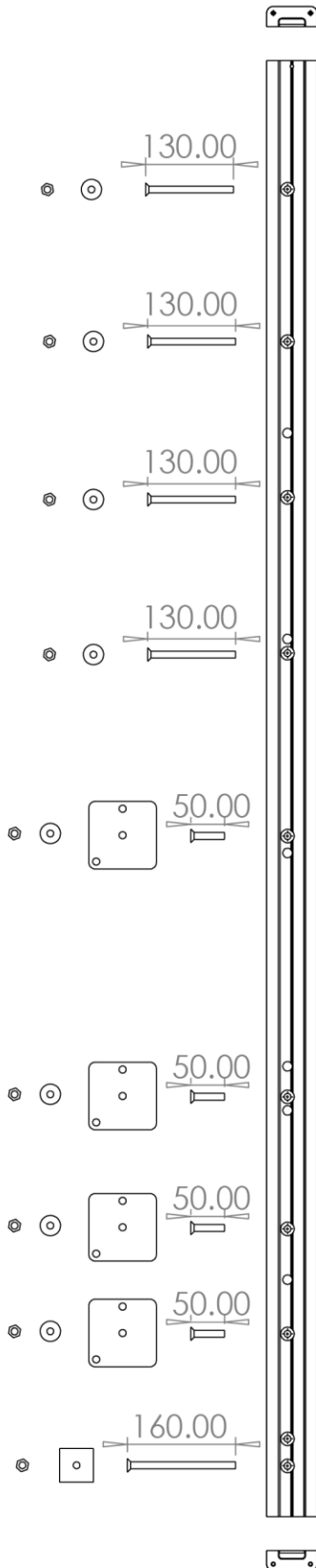
Back

RIB 150 Glidemotion SWB T5/6 Fixings Guide

Passenger Side

Drivers Side

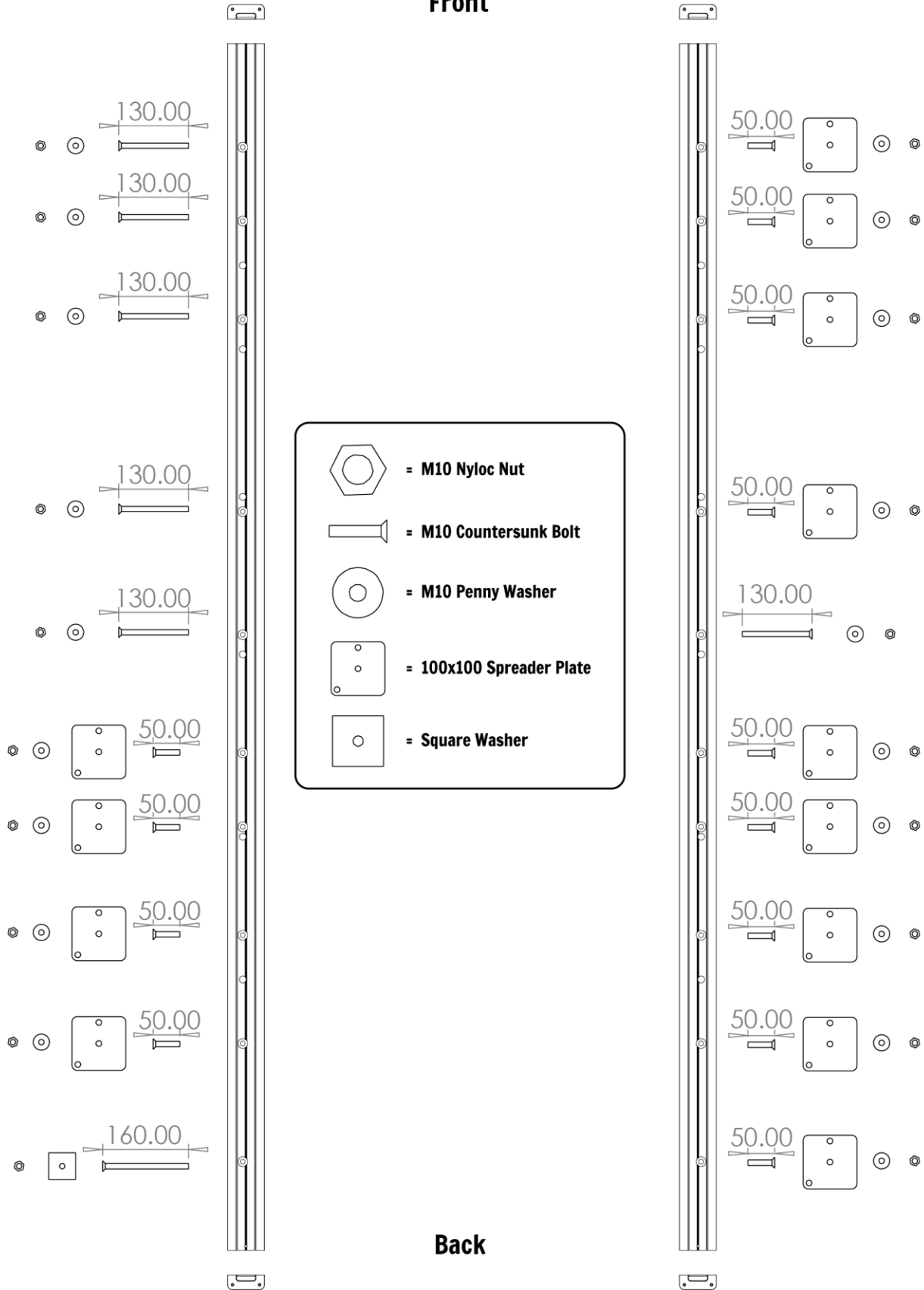
Front



Back

RIB 150 Glidemotion LWB T5/6 Fixings Guide

Front



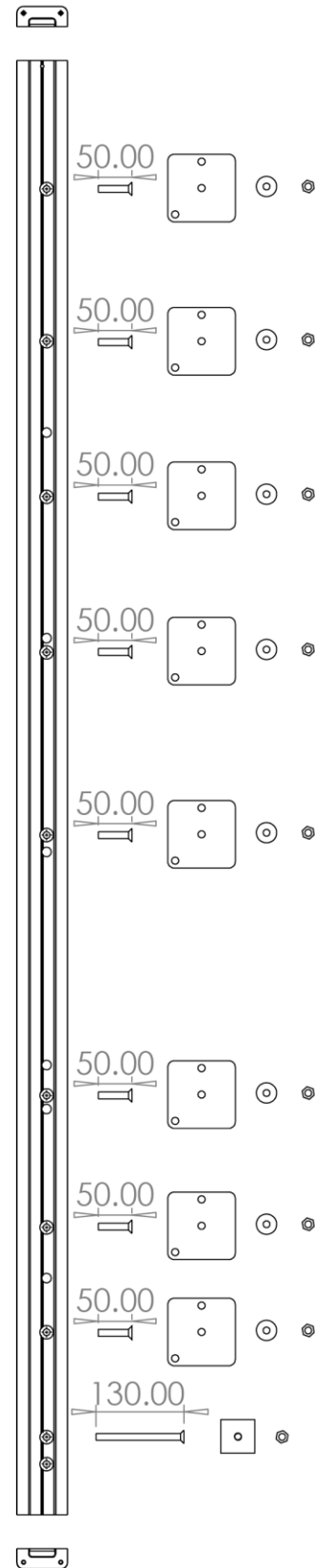
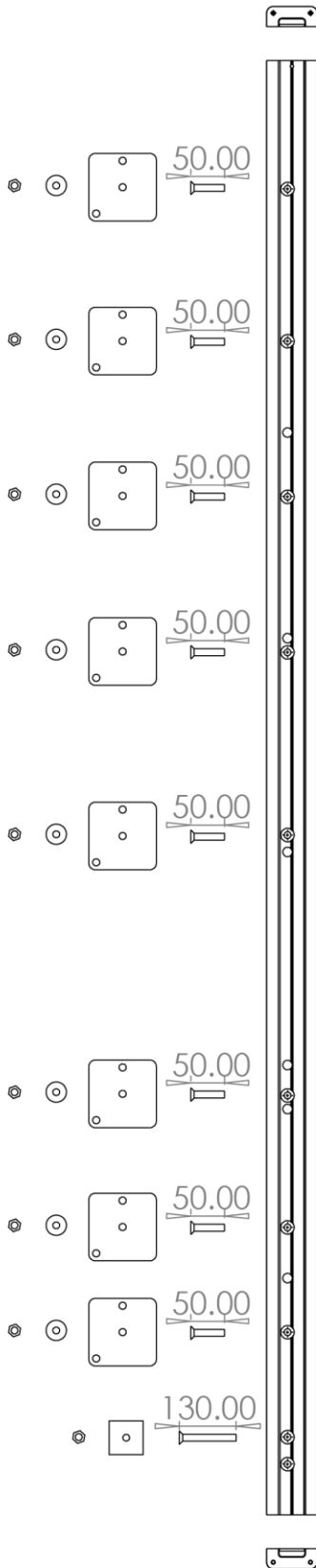
Back






RIB 112 Glidemotion SWB Transit Custom Fixings Guide

Passenger Side

Drivers Side

Front

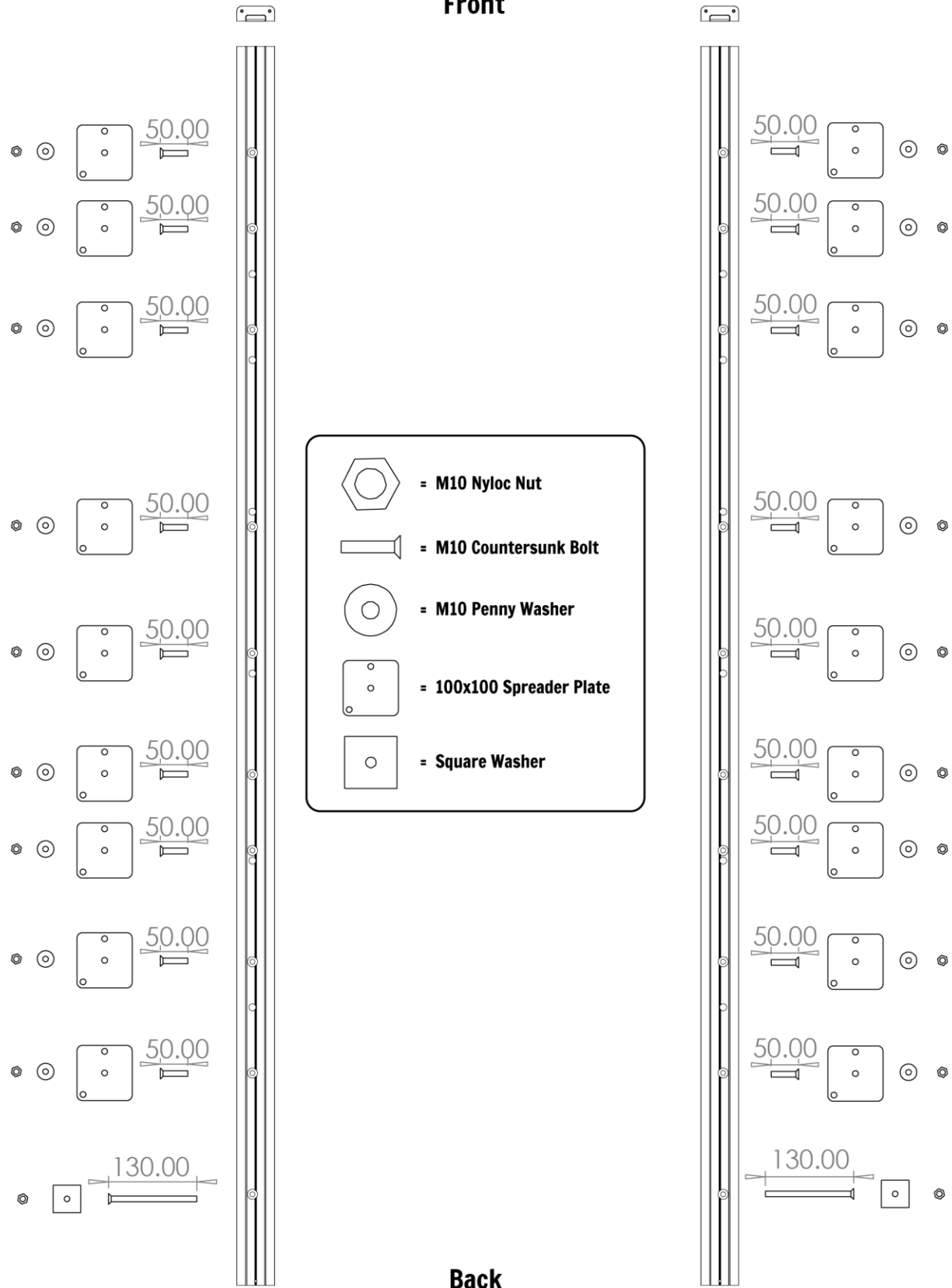


	= M10 Nyloc Nut
	= M10 Countersunk Bolt
	= M10 Penny Washer
	= 100x100 Spreader Plate
	= Square Washer

Back

RIB 112 Glidemotion LWB Transit Custom Fixings Guide

Front



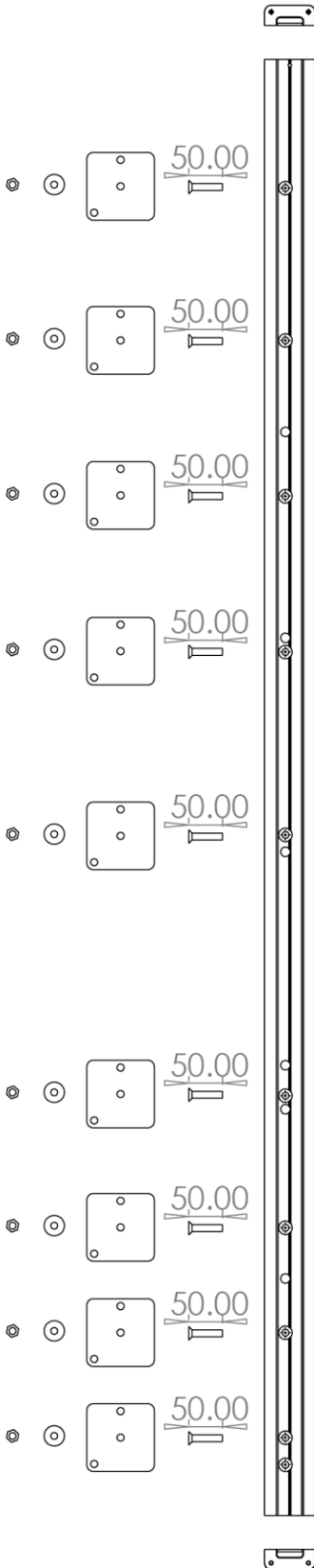
Back






RIB 120 Glidemotion SWB Transit Custom Fixings Guide

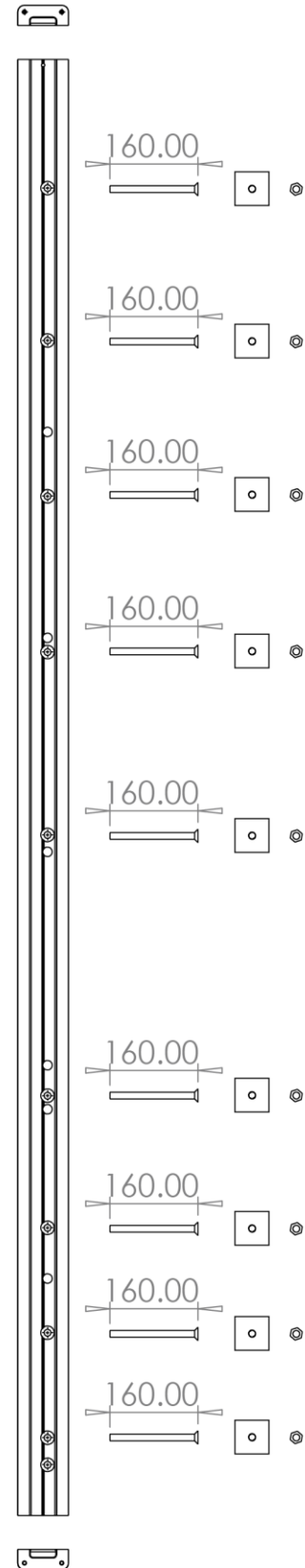
Passenger Side

Drivers Side

Front



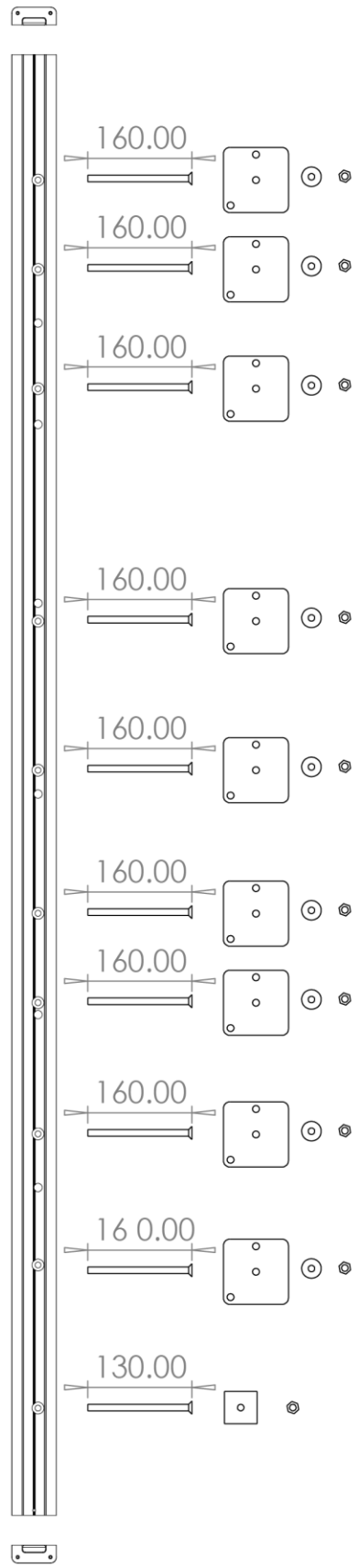
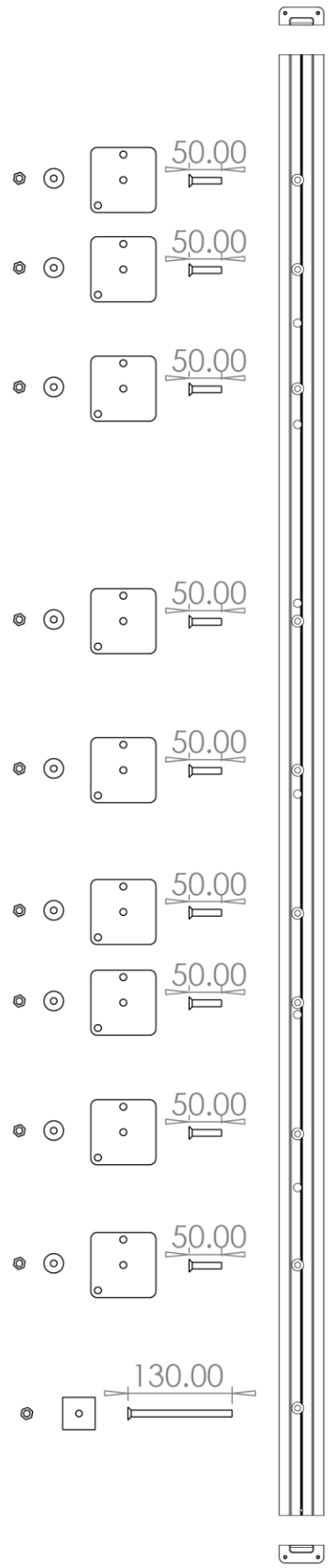
	= M10 Nyloc Nut
	= M10 Countersunk Bolt
	= M10 Penny Washer
	= 100x100 Spreader Plate
	= Square Washer








Back

RIB 120 Glidemotion LWB Transit Custom Fixings Guide

Front



-  = M10 Nyloc Nut
-  = M10 Countersunk Bolt
-  = M10 Penny Washer
-  = 100x100 Spreader Plate
-  = Square Washer

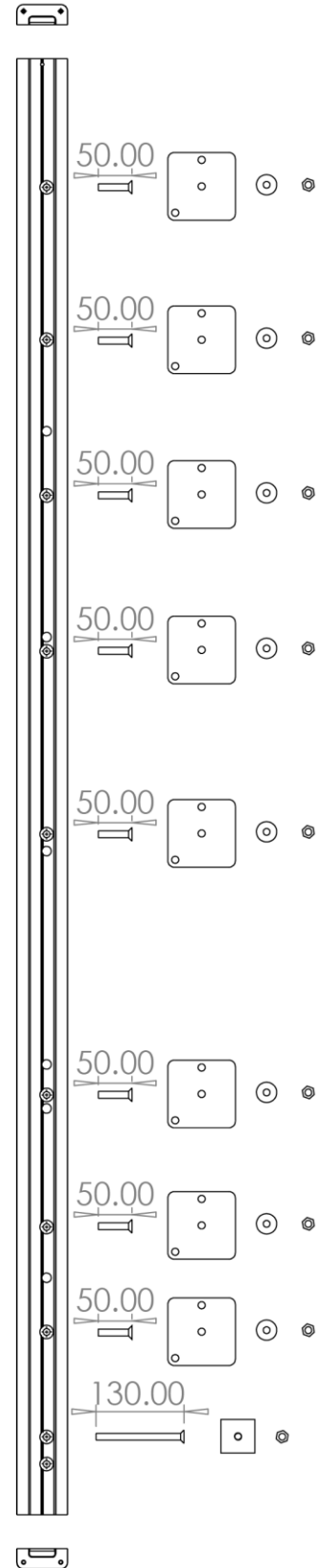
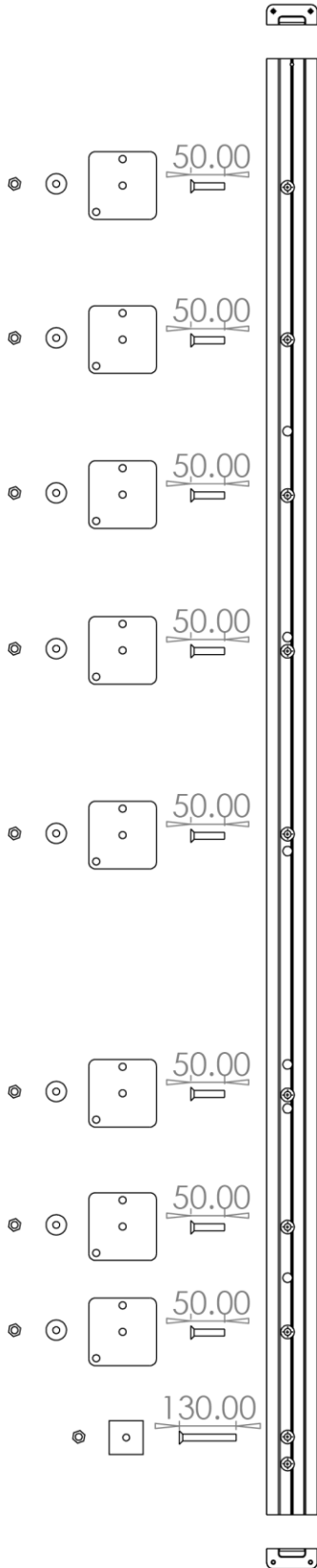
Back






RIB 150 Glidemotion SWB Transit Custom Fixings Guide

Passenger Side

Drivers Side

Front

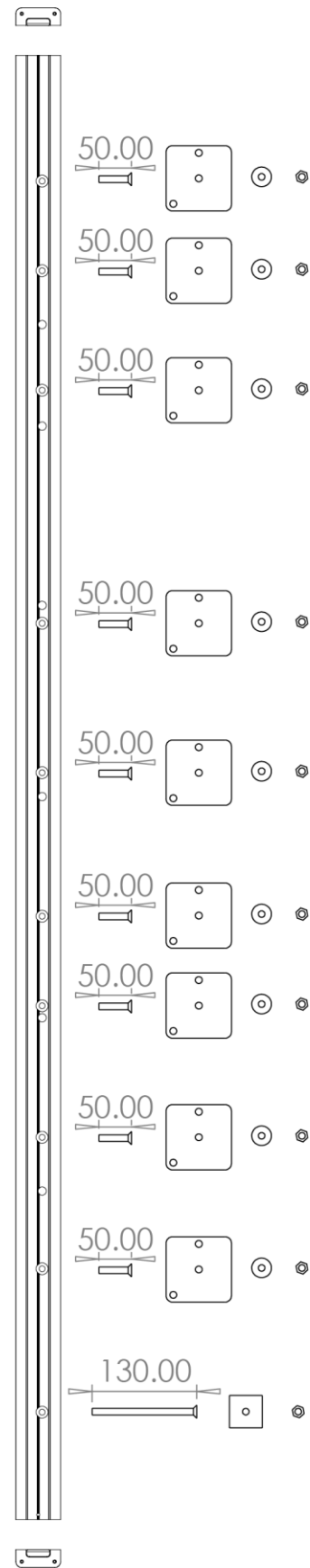
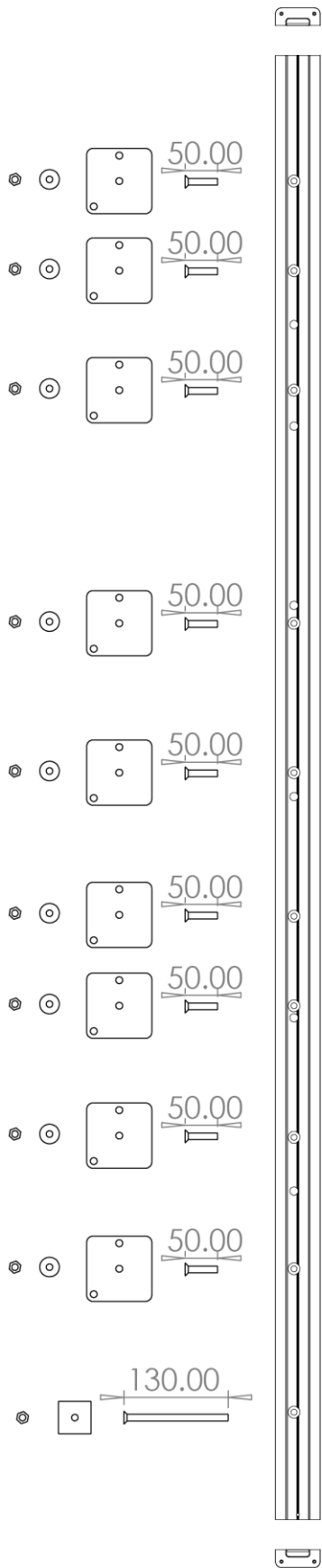







	= M10 Nyloc Nut
	= M10 Countersunk Bolt
	= M10 Penny Washer
	= 100x100 Spreader Plate
	= Square Washer

Back

RIB 150 Glidemotion LWB Transit Custom Fixings Guide

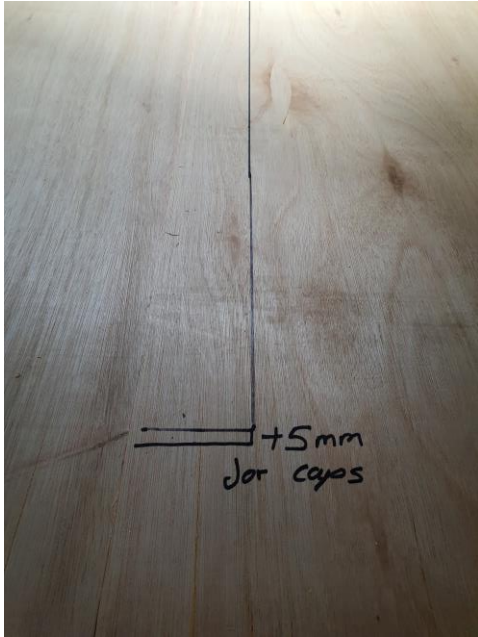
Front



	= M10 Nyloc Nut
	= M10 Countersunk Bolt
	= M10 Penny Washer
	= 100x100 Spreader Plate
	= Square Washer

Back

Useful tips



After you have drawn around the rails, add a 5mm gap at either end to allow for slotting in the rail endcaps easily.



To ensure an easier time when laying the Altro floor covering you will want to cut back the plastics using a multi tool or similar.

Useful tips



N.B The images above show the “ideal” method for laying and prepping the floor with additional packers and insulation cut to shape/size (not supplied)
Alternatively, you can just lay the insulation all through and cut out the required sections for the rails to sit.

01271 373853

enquiries@clearcutconversions.co.uk

www.clearcutconversions.co.uk